

IV – 3. Pile drivers and pile extractors

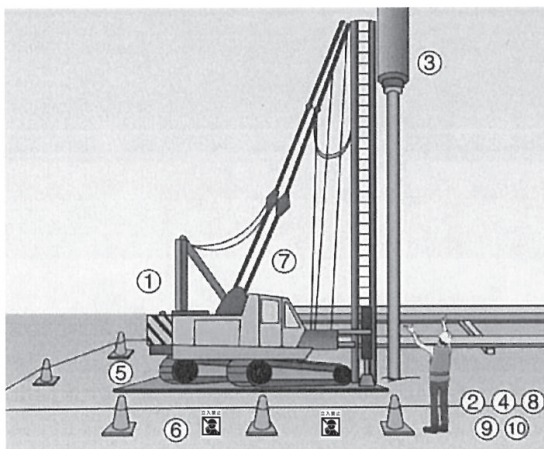

1. Are operators appropriately licensed?
2. Is piling work conducted based on a work plan and procedures?
3. Are the clutch, brakes, and hoisting wire in proper condition?
4. Are signals standardized?
5. Are steel plates used under the pile driver?
6. Have barricades been set up to stop other workers from approaching?
7. Are operators stopping the engine when leaving the driver's seat?
Is the hammer lowered?
Are the brakes applied?
8. Has an operations chief been stationed during assembly and moving?
9. Has a lookout been stationed?
Have signalmen been stationed?
10. Have signalmen been designated?